

Instructions for Use

Floor Boxes

Copyright

© 2020 A-dec Inc. All rights reserved.

A-dec Inc. makes no warranty of any kind with regard to this material, including, but not limited to, the implied warranties of merchantability and fitness for a particular purpose. A-dec Inc. shall not be held liable for any errors contained herein or any consequential or other damages concerning the furnishing, performance or use of this material. The information in this document is subject to change without notice. If you find any problems in the documentation, please report them to us in writing. A-dec Inc. does not warrant that this document is error-free.

No part of this document may be copied, reproduced, altered, or transmitted in any form or by any means, electronic or mechanical, including photocopying, recording, or by any information storage and retrieval system, without prior written permission from A-dec Inc.

Trademarks and Additional Intellectual Property Rights

A-dec, the A-dec logo, A-dec 500, A-dec 300, Cascade, Cascade Master Series, Century Plus, Continental, Decade, ICX, ICV, Performer, Preference, Preference Collection, Preference ICC, and Radius are trademarks of A-dec Inc. and are registered in the United States and other countries. A-dec 400, A-dec 200, Preference Slimline, and reliablecreativesolutions are also trademarks of A-dec Inc. None of the trademarks or trade names in this document may be reproduced, copied, or manipulated in any manner without the express, written approval of the trademark owner.

Certain touchpad symbols are proprietary to A-dec Inc. Any use of these symbols, in whole or in part, without the express written consent of A-dec Inc., is strictly prohibited.

Regulatory Information

Regulatory information mandated by agency requirements is provided in the *Regulatory Information, Specifications, and Warranty* document (p/n 86.0221.00), which is available in the Document Library at www.a-dec.com.

Product Service

Product service is available through your local authorized A-dec dealer. For service information, or to locate an authorized dealer, contact A-dec at 1.800.547.1883 in the USA and Canada or 1.503.538.7478 worldwide, or visit www.a-dec.com.

Contents

About Your Floor Box	1
Controls	1
Air and Water Manual Shutoff Valves	3
Air-Actuated Air and Water Shutoff Valves	3
Air and Water Filters.....	3
Air and Water Pressure Pre-Regulators.....	3
Power Supply	4
Gravity Drain and Air Vent	4
Vacuum Outlet.....	5
System Air and Water Pressure Adjustments.....	6
Checking for a Clogged Air Filter	7
Checking for a Clogged Water Filter	7
Filter Maintenance	8
Air and Water Filter Elements	8
Inspecting the Filters	8
Water Screen.....	9
Maintenance	10
Adjustments and Specifications	10

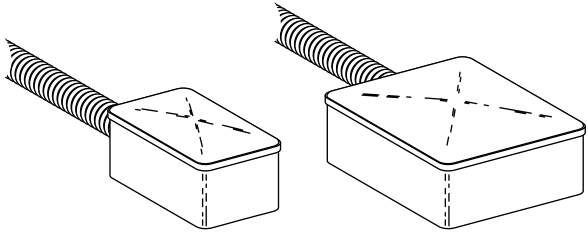

Medium Stainless Steel
(9" X 14")

Large Stainless Steel
(14.5" X 17")

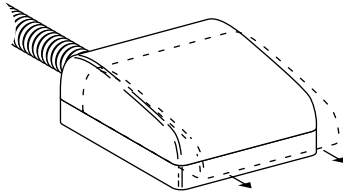

Cascade®
(14.5" X 17")

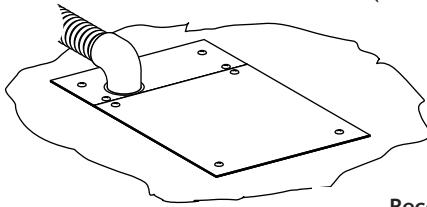

Recessed
(14.5" X 18")

Floor Boxes

About Your Floor Box

Your Cascade, recessed, or stainless steel floor box is mounted over the utilities on the floor or wall of the operatory. Located in the floor box are the air and water manual shutoff valves, filters, and pressure pre-regulators. You will find vacuum or gravity drains as well as electrical outlets.

The stainless steel floor box covers lift off for access to the utilities and optional power supplies and/or water heater.

To remove the cover from your Cascade Floor Box, slide the cover forward a little and lift.

The recessed floor box cover is held in place by four screws. Removing the screws will allow you to lift the cover.

Controls

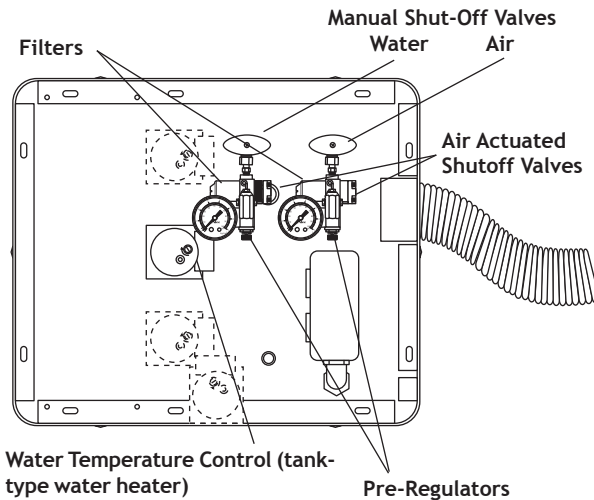

Figure 1. Cascade and Large Floor Boxes

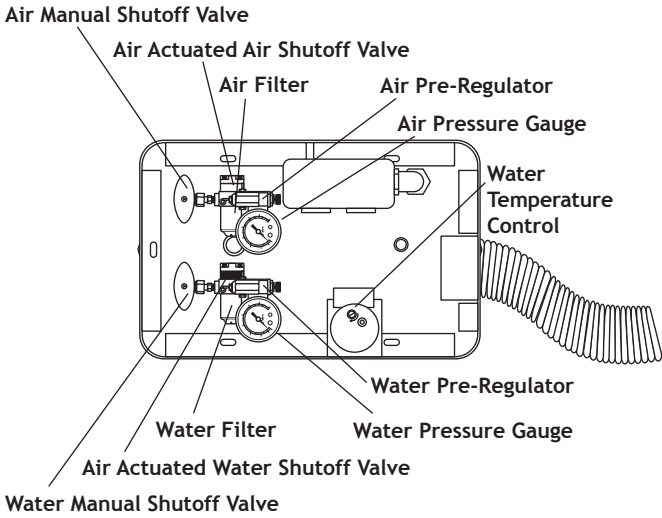

Figure 2. Medium Floor Box

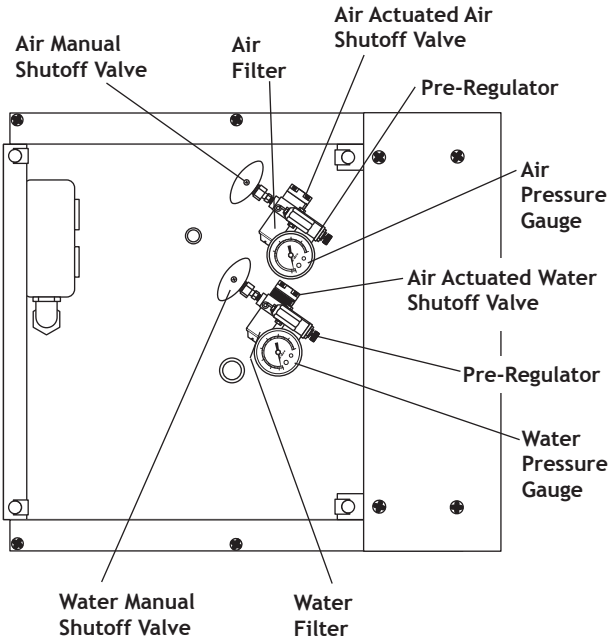

Figure 3. Recessed Floor Box

Air and Water Manual Shutoff Valves

Shutoff valves control the air and water to the unit. To prevent leaks, these valves should remain fully open (turned counterclockwise) except while your unit is being serviced.

Air-Actuated Air and Water Shutoff Valves

The air-actuated air and water shutoff valves automatically shut off air and water to the system when the master on/off toggle is in the Off position. This safety feature prevents water damage in the event the unit should develop a water leak while the unit is unattended.

Air and Water Filters

Filters prevent solids from entering the unit. The procedures for checking and replacing the filters are given beginning on page 8.

Air and Water Pressure Pre-Regulators

Pre-regulators control the air and water pressures in the unit. The procedure for adjusting system pressure begins on page 6.

Power Supply

Your system may include A-dec's 25 watt power supply or 300 watt power supply. No cleaning or maintenance is required to maintain the power supply.

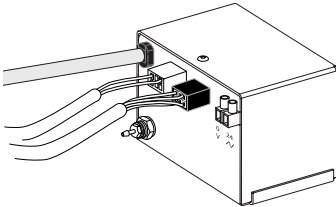

25 Watt Power Supply

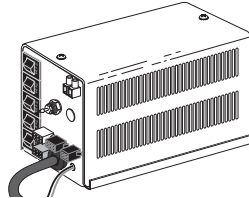

300 Watt Power Supply



NOTE The master on/off toggle switches the control head, dental light, auxiliary cable, and the indicator light on or off.

If a problem arises with the power supply or an A-dec electrical accessory to the power supply, call your authorized A-dec dealer.

Gravity Drain and Air Vent

The Gravity Drain (a "T" fitting) (see Figure 6) is connected to the office waste drainage system and provides for the disposal of water and debris from the unit.

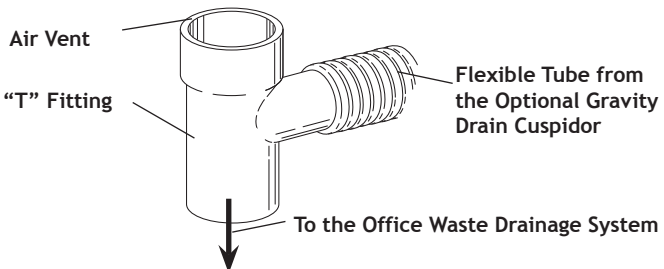

Figure 4. Gravity Drain and Air Vent

The Air Vent (the open end of the “T” fitting) prevents air being trapped in the office waste drainage system. If the vent becomes obstructed, waste water and debris may backup into the unit.

If A-dec’s optional circulating warm water syringe is included with your unit, a water drip tube will be positioned over the drain air vent. The drip tube is the outlet for warm water supplied to your syringe by the water heater. For more information about your syringe, refer to your *A-dec Syringes Instructions for Use*, p/n 85.0680.00.

If your A-dec unit includes a support center with cuspidor, a flexible tube from the cuspidor will be connected to the gravity drain. For information about the cuspidor, refer to the *Cascade 7284 and Radius 7284 Owner's Guide*, p/n 85.2069.00, or the *A-dec 300, 400, and 500 Delivery Systems Service Guide*, p/n 86.0382.00.

Vacuum Outlet

The office central vacuum system outlet is located in the floor box. A flexible tube connects your vacuum instruments and optional Decade vacuum cuspidor to the outlet.

System Air and Water Pressure Adjustments

The air and water pre-regulators are located in the floor box. Before making any adjustments, verify that the air compressor is turned on, and that it maintains 80–100 psi pressure in the tank. If it doesn't, refer to the compressor instructions.



NOTE When decreasing system air or water pressure, you will not see the air or water pressure gauge in the floor box change until you relieve pressure from the system. Activate the syringe for a few seconds, then check the gauge. Repeat this process each time you make an adjustment to decrease pressure.

1. Be sure that the manual shutoff valves are fully open (counterclockwise). Turn the system on and check the pressure gauges in the floor box (see Figures 7 and 8). Air pressure should be 70–80 psi while water pressure should be 35–40 psi.

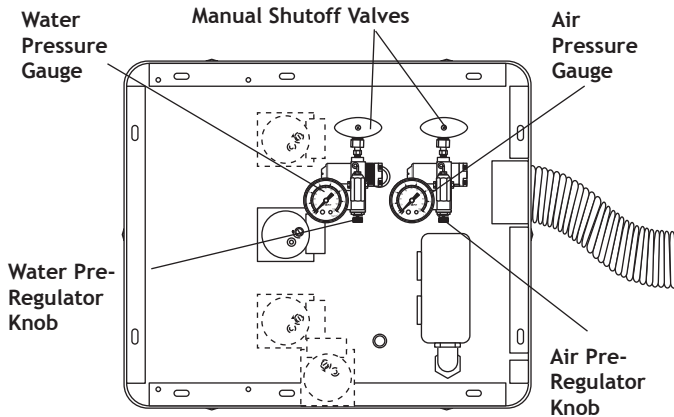

Figure 5. Cascade and Large Floor Box

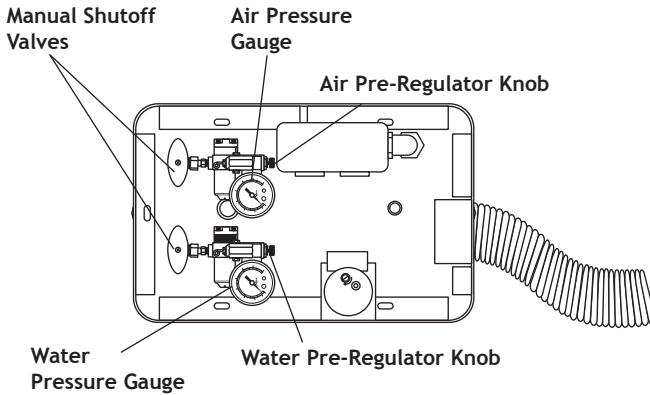

Figure 6. Medium Floor Box

2. While watching the gauges, operate the syringe. If the system air pressure drops by any more than 15 psi, or water pressure by more than 10 psi, check for clogged filters.
3. If adjustment of either the air or water pressure is required, turn the appropriate pre-regulator knob clockwise to increase pressure, or counterclockwise to decrease.

Air and water pass through separate filters before entering the regulators. A filter must be replaced when it becomes sufficiently clogged causing restricted flow to the regulator.

Checking for a Clogged Air Filter

To check for a clogged air filter, flip the master on-off toggle to the ON position and remove the floor box cover. While watching the air pressure gauge in the floor box (see Figures 7 and 8), press the syringe air button. If the air pressure indicated by the gauge drops by more than 15 psi, the filter element is clogged and must be replaced.

Checking for a Clogged Water Filter

To check for a clogged water filter, flip the master on-off toggle on the control head to the ON position, then remove the floor box cover. Watch the water gauge, press the

syringe water button. If the water pressure drops by more than 10 psi, the water filter is clogged and must be replaced.

Filter Maintenance

Air and Water Filter Elements

Inspecting the Filters

To inspect or replace a filter element, flip the master on-off toggle to the OFF position, then close the manual shutoff valves. Bleed the system of air and water pressure by operating the syringe buttons until air and water no longer flow. Using a standard (flat-blade) screwdriver, remove the filter housing from the air and/or water pre-regulators assemblies (see Figure 9) and remove the filter.

If the filter is visibly clogged or discolored, you will need to replace it.

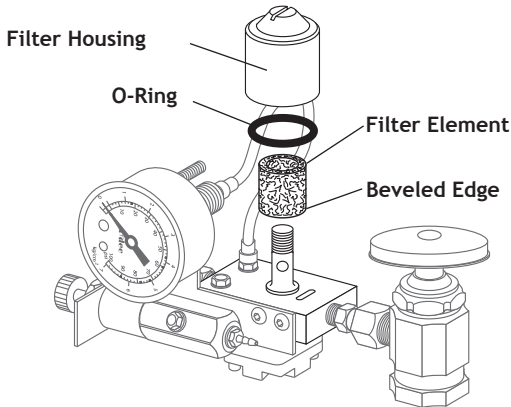

Figure 7. Air or Water Filter Replacement

When installing a new filter, notice that one end of the filter has a beveled edge. Install the filter with the beveled edge facing the manifold (see Figure 9). The system will not work properly if the filter is installed incorrectly.

Water Screen

The manual water shutoff valve in your floor box (see Figure 10) is equipped with a screen to prevent debris from entering the system. You should periodically check and replace this screen to ensure unrestricted water flow to your unit.

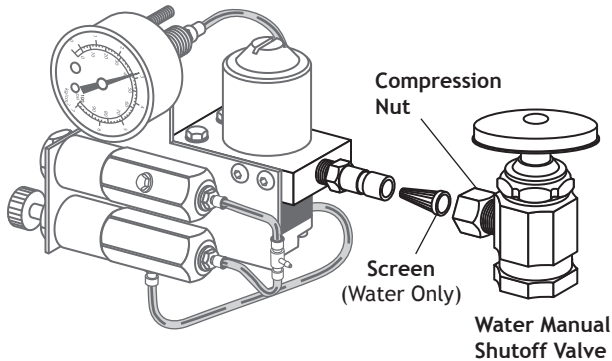

Figure 8. Water Screen Replacement

To remove or replace a screen, first move the master on/off toggle to the OFF position and close the manual water shutoff valve.

Now, using a 5/8" or adjustable wrench, loosen the compression nut on the manual water shutoff valve and pull the water regulator out of the shutoff valve (see Figure 10). Remove the screen and install the replacement screen.

Reposition the water regulator in the manual shutoff valve outlet and tighten the compression nut. Open the manual water shutoff valve and flip the master toggle to the ON position. Check the fittings for leaks.

Maintenance

System Air and Water Pressure Adjustments	page 6
Filter Maintenance	page 8

Adjustments and Specifications

Minimum air, water, and vacuum service requirements for proper unit operation:

- Air: 2.50 cfm (70.80 l/min) at 80 psi (551 kPa).
- Water: 1.50 gpm (5.68 l/min) at 40 psi (276 kPa).
- Vacuum: 12 cfm (339.84 l/min) at 8 inches (27 kPa) of mercury.



NOTE Specifications are subject to change without notice. Some requirements may vary from country to country. For more information, contact your authorized A-dec dealer.

Warranty

Warranty information is provided in the *Regulatory Information, Specifications, and Warranty* document (p/n 86.0221.00), which is available in the Document Library at www.a-dec.com.



A-dec Headquarters

2601 Crestview Drive
Newberg, Oregon 97132
United States
Tel: 1.800.547.1883 within USA/CAN
Tel: +1.503.538.7478 outside USA/CAN
www.a-dec.com

A-dec Australia

Unit 8
5-9 Ricketty Street
Mascot, NSW 2020
Australia
Tel: 1.800.225.010 within AUS
Tel: +61.(0).2.8332.4000 outside AUS

A-dec China

A-dec (Hangzhou) Dental Equipment Co., Ltd.
528 Shunfeng Road
Qianjiang Economic Development Zone
Hangzhou 311100, Zhejiang, China
Tel: 400.600.5434 within China
Tel: +86.571.89026088 outside China

A-dec United Kingdom

Austin House
11 Liberty Way
Nuneaton, Warwickshire CV11 6RZ
England
Tel: 0800.ADEC.UK (2332.85) within UK
Tel: +44.(0).24.7635.0901 outside UK



85.2611.00 Rev R

Date of Issue 2020-02-24
Copyright 2020 A-dec Inc.
All Rights Reserved.